



Commercial Trash and Recycling Guidelines

- Customer warrants that the container service area and all right-of-ways for servicing equipment is sufficient to bear the weight of all equipment/vehicles required to perform the designated services. CWD does not accept liability for concrete or asphalt failure. Commercial Vehicle gross weight is 54,000 lbs, axle weight is 20,000 lbs with a 10,000 lb single wheel load. All container service areas must be on flat level surfaces.
- Customer warrants that any right-of-way provided for servicing equipment is of sufficient width and length (minimum 12' width with sufficient swept path clearances to negotiate turns, entrances/exits, etc.) to provide access to all equipment, vehicles and personnel access required to perform the designated services. Commercial Vehicle length is 35.6 feet with a 210-inch wheelbase for Front Load trucks and 33 feet with 278-inch wheelbase for Roll Off trucks. Wall to wall turning radius is 78 feet for Front Load/Side Load and 84 feet for Roll Off. There must be 70 feet of unobstructed approach (truck length + approach clearance) in front of each container for Front Load service and 100 feet unobstructed approach (truck length + service clearance) for Roll Off container service.
- Customer warrants that any right-of-way provided for servicing equipment is free from all obstructions that may interfere with servicing the container, including sufficient vehicle/driver access clearance areas and unobstructed visibility. Overhead ceilings, roofs, wires, pipes, or other obstructions must be a minimum of 14 feet above ground/service level at the lowest point on approach, and 25 feet of unobstructed clearance above the service location. Some configurations may require additional clearance space. CWD does not accept liability for damage to ceilings, roofs, wires, pipes, or other obstructions with insufficient clearances. Landscaping/vegetation must be planted with consideration for future growth potential.
- CWD does not accept liability for damage caused to automatic vehicular gates if they close against the service vehicle during entry/exit. Property access barriers, including automatic vehicular gates/arms, shall be equipped with a reversing Inherent Entrapment Sensing System (ground loop, magnetic, eye sensor, or other) installed, capable of detecting vehicles in both opening and closing cycles to prevent gate closure on entrapped vehicles. Due to increased risk of entrapped vehicles, vehicular gates with split entry/exit sides that swing in opposite directions are strongly discouraged. Service vehicles may be required to drive in the middle of two gates in order to have sufficient approach for entry/exit. Split entry gates must have appropriate entrapment devices installed to recognize a vehicle in the middle of the two gates. Gates/arms must have sufficient time allowed for slow-moving vehicle entrance/exit with a recommended minimum duration of 15 seconds. Proper access codes or remote activation device must be provided for service access.
- Front Load Enclosures must contain a minimum of 10 feet x 10 feet inside dimensions (*two containers in shared enclosure must be a minimum of 20 feet wide*) to provide reasonable safe clearance for servicing. Access doors/gates must be mounted to provide a minimum 10 feet wide unobstructed opening to the enclosure (*20 feet for two containers in shared enclosure*), have a 120-degree swing opening radius, and must be securable in both the open and closed positions. Enclosures should not be covered (open to the sky) above the container.
- Side Load Enclosures must be a minimum of 8 feet wide by 8 feet deep to provide reasonable safe clearance for servicing. Access gates/doors must be a minimum of 8 feet wide with a 180-degree swing opening and be capable of being secured in both the open and closed positions.
- Roll-Off Enclosures must accommodate a minimum of 2 feet clearance on each side of the container and 2 feet clearance in the front and rear of the container. Access gates/doors must be a minimum of 12 feet wide with a 120-degree swing opening and be capable of being secured in both the open and closed positions. (See compactor size diagrams for more information)
- Heavy-duty cane bolts of at least ½" diameter are recommended to be installed on both doors to secure them in the open/closed positions. The cane bolts shall smoothly and securely drop into the ground a minimum of 3 inches. Bollards or concrete wheel stops are recommended to be installed inside the enclosure to prevent containers from coming into contact with the back of the

enclosure. For metal enclosure doors/gates, three heavy-duty hinges per door are required to support the weight of the gates over the lifetime of the enclosure.

- All enclosure hardware (including access gates, doors, hinges, cane bolts, etc) must be of sufficient design and strength to accommodate repetitive use. Regular inspections and maintenance should be performed to ensure proper operation and to prevent hardware failure.
- Additional equipment, containers, or other items stored inside the enclosure must be kept a minimum of 2 feet away from each side, and 3 feet away from the rear of the dumpster container. CWD does not accept liability for grease container spills if the grease containers are stored inside the enclosure unsecured from the normal dumpster service area.
- All containers without enclosures must have a 3-foot obstruction-free clearance zone surrounding the container. This includes vehicles, poles, buildings, and any other obstructions. Containers located behind overhead/roll up doors are subject to the same minimum clearance requirements as containers inside enclosures.
- Containers on casters may not exceed 4 yards in size and must be limited to a required maneuverable distance of less than 25 feet. A smooth, flat, and level surface must be provided for all pathways the container must be maneuvered and will be expected to travel. Customer is responsible for securing containers on casters and preventing them from rolling when the containers are onsite but not immediately being serviced.
- All trash/recycle items must fit inside the container and not extend above the lip of the container. CWD is not responsible for damage caused by (or from) items left outside or on top of the container, or damage caused from servicing overloaded/overweight containers. Customer is responsible for any and all citations resulting from servicing/transporting overloaded/overweight containers.
- Building developer shall ensure that all additional enclosure dimensions and construction material meet the construction requirements of the local City Land Development Code. Customers with enclosures that will also be housing other non-trash/recycle serviceable containers (grease traps, oil containers, etc) must provide additional space to accommodate bollards to separate the regular trash/recycle container and the other container, plus a two-foot clearance (on each side) between the bollards and both containers. All drains/covers located inside the enclosure must have prior approval from the City. All enclosure walls must be 8-foot minimum height and uncovered (open to the sky).

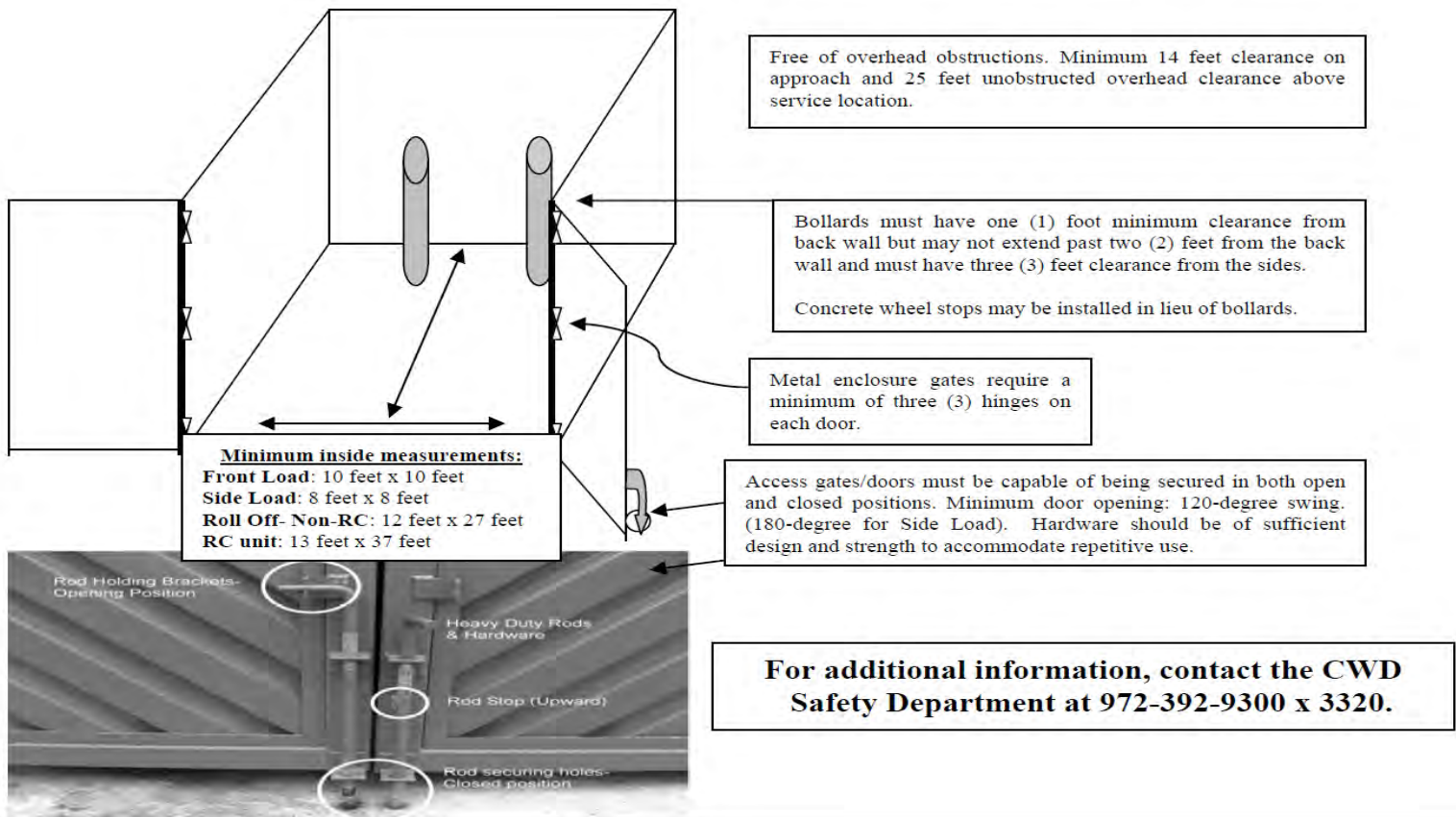

Front Load Service

Container Dimensions:

Width- Length- Height

4 cubic yard dumpster 84" 60" 63"

6 cubic yard dumpster 84" 67" 72"

8 cubic yard dumpster 84" 72" 77"

*Sizes are approximate and may vary by manufacturer.

One cubic yard = 170 gallons

Height is measured with the lids. Lids must remain closed at all times except when the container is being loaded or unloaded. When lids are raised, full height from the ground to the top of lids may extend to 130".

Required Clearance for Front End Loading Vehicles:

Vertical (Approach and Exit) 14' High

Vertical (When dumping container) 25' High

Lateral Sixteen 16' Wide

Outside Turning Radius 78' - (84' feet in pick-up/service position)

Length of Vehicle 33' - (37' in pick-up/service position)

Side Load Service

Container Dimensions:

Width- Length- Height

3 cubic yard dumpster 60" 60" 52"

4 cubic yard dumpster 30" 66" 62"

*Sizes are approximate and may vary by manufacturer.

One cubic yard = 170 gallons

Height is measured with the lids. Lids must remain closed at all time except when the container is being loaded or unloaded. When lids are raised, full height from the ground to the top of lids may extend to 90".

Required Clearance for Side Loading Vehicles:

Vertical (Approach and Exit) 14' High

Vertical (When dumping container) 20' High

Lateral 12' Wide

Outside Turning Radius 78'

Length of Vehicle 33'

Roll Off – Open Top/Compactor Service

Open Top Dimensions:

40 Yard	30 Yard
---------	---------

Length: 22'	Length: 22'
-------------	-------------

Width: 8'	Width: 8'
-----------	-----------

Height: 8'	Height: 6'
------------	------------

*Sizes are approximate and may vary.

Required Clearance for Roll Off Vehicles:

Vertical (Approach and Exit) 14' High

Vertical (When loading or unloading container) 25' High

Lateral 12' Wide

Service Area length 70' long

Outside Turning Radius 84'

Length of Vehicle 33'

FRONT LOADING CONTAINERS

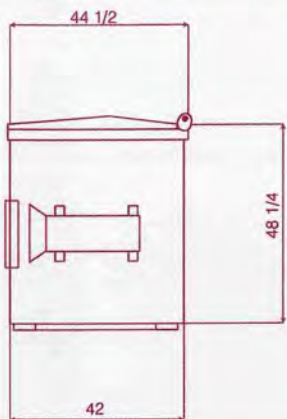
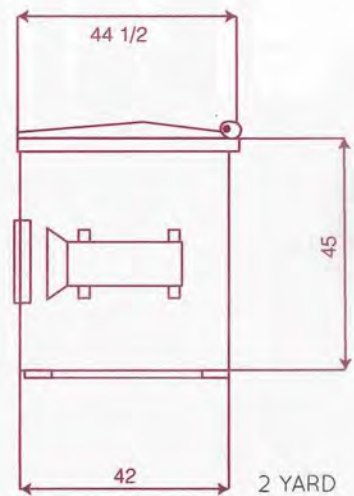
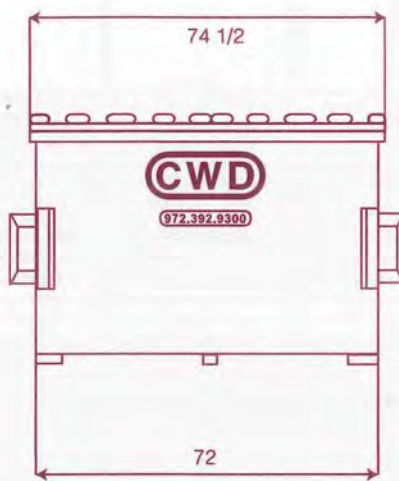

3 YARD

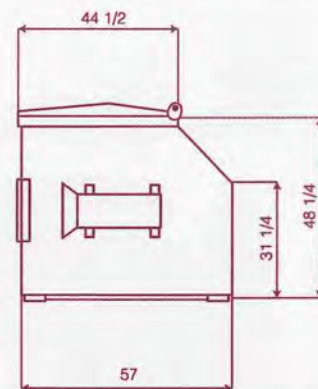
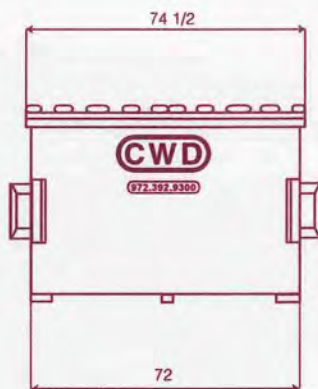
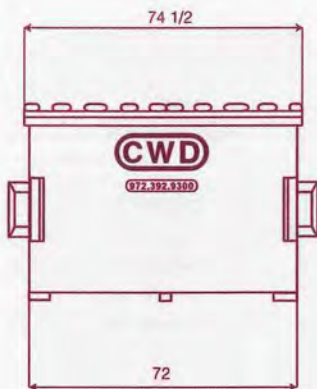

4 YARD



6 YARD SLANT

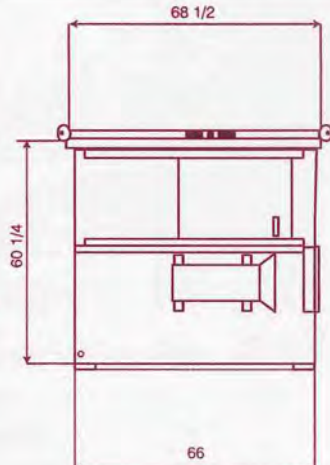
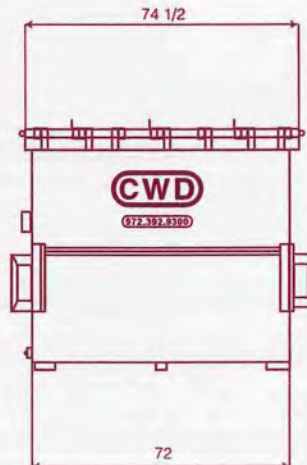
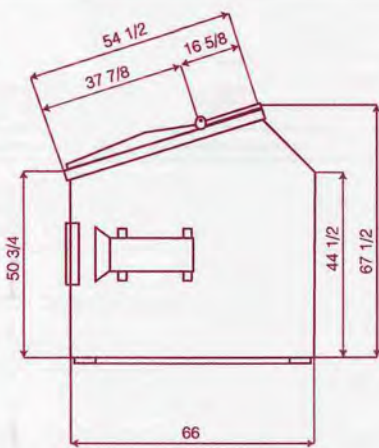

6 YARD

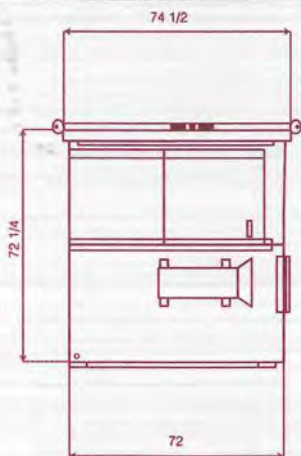
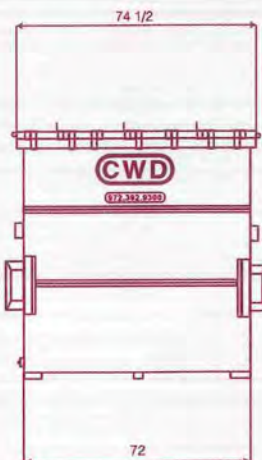

8 YARD

All containers are manufactured from the highest quality materials to provide years of dependable service. Different styles are available and can be tailored to your waste disposal needs.



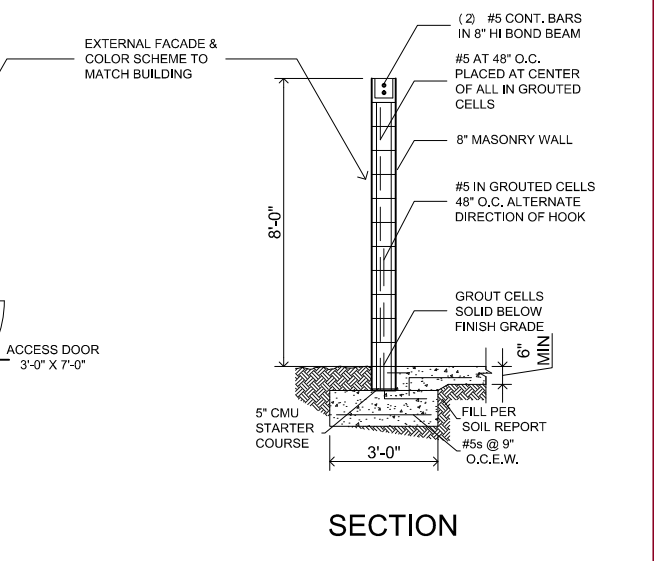
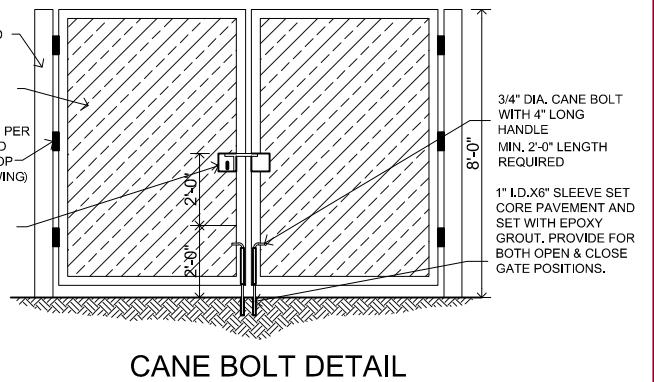
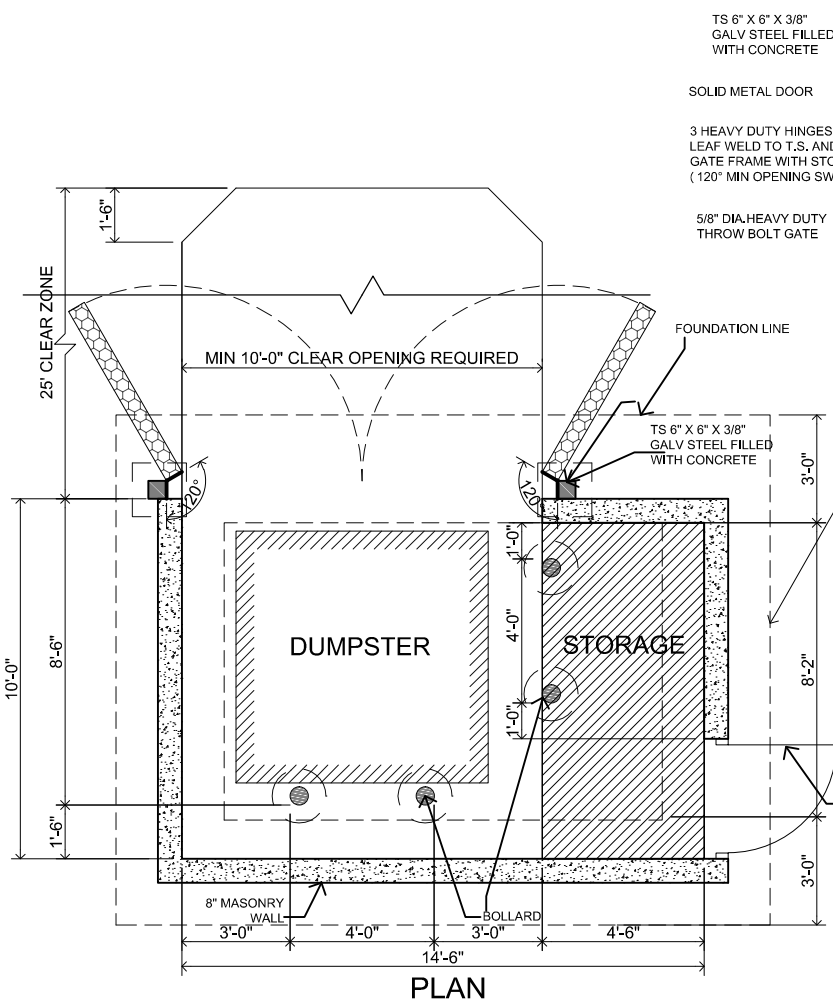
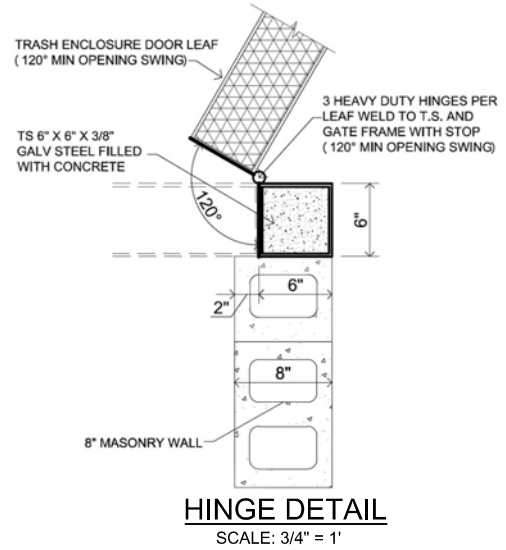
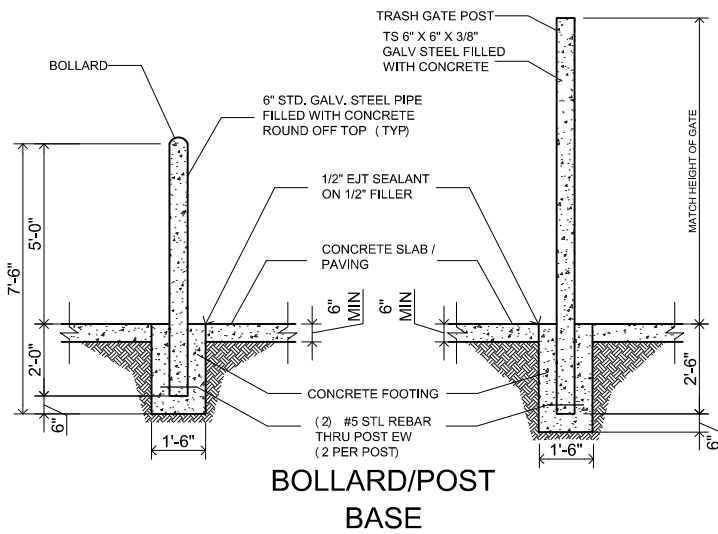

The information in this report is confidential and may be legally privileged. It is intended solely for the internal use of Community Waste Disposal, L.P. (CWD). Access to the information contained within this report by anyone else is unauthorized. Any disclosure, copying, distribution or action taken or omitted based on this information is prohibited and maybe unlawful.

Community Waste Disposal
 Since 1984
 2010 California Crossing Road
 Dallas, Texas 75220-2810
 972.392.9300 • 817.795.9300
 972.392.9301

**SINGLE DUMPSTER
WITH STORAGE**

AUGUST 23 2018

**GUIDELINES
SCALE: 3/16" = 1'**

SRG Architects, LLC
 TBAE FIRM #BR 2117
 www.sarrogroup.com
 Ph: 882.708.3161
 6421 Camp Bowie Blvd., Suite 312
 Fort Worth, Texas 76116
 Copyright © 2018 SRG Architects, LLC

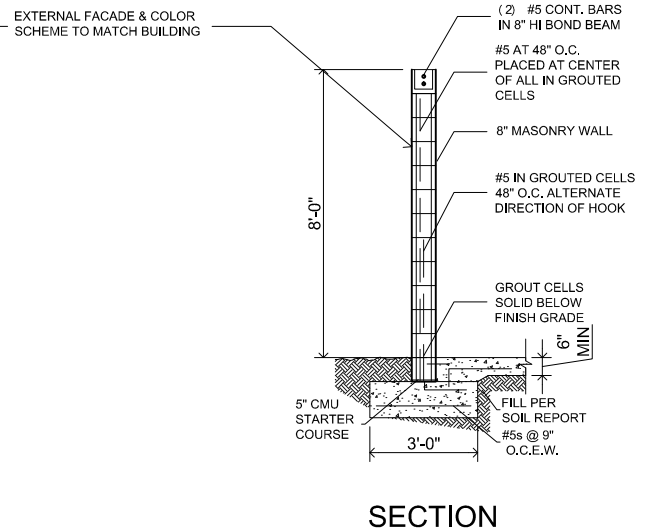
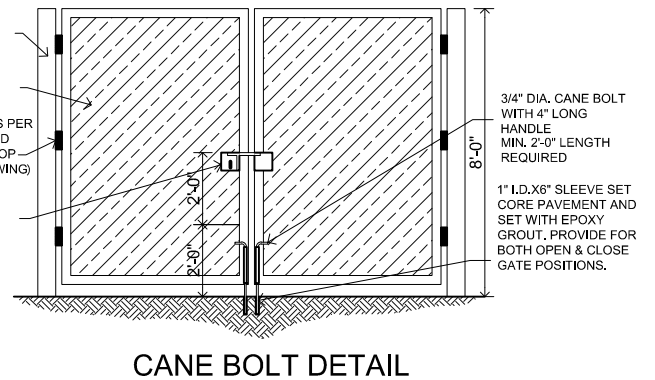
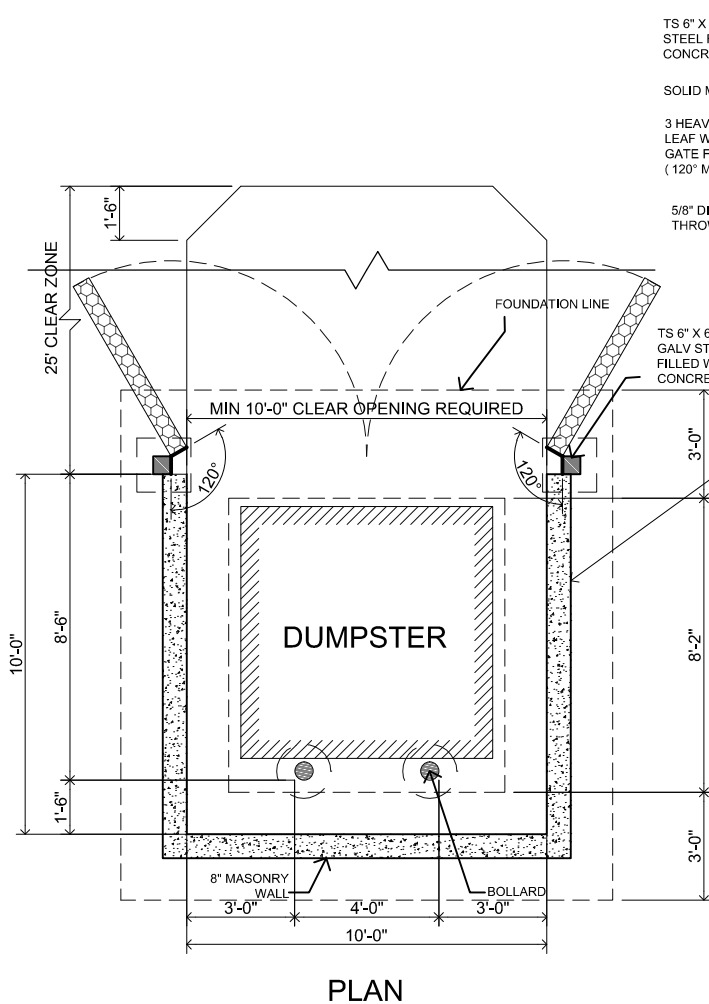
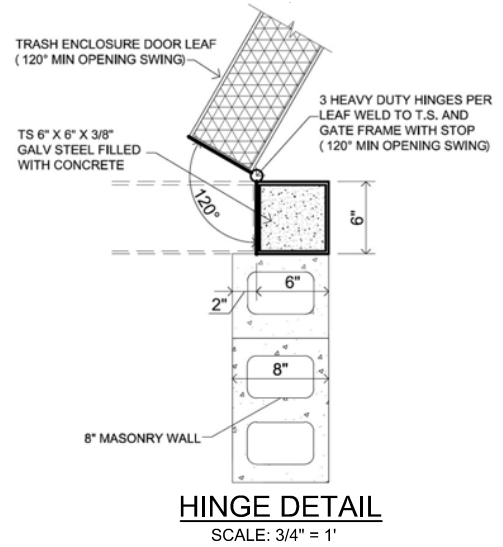
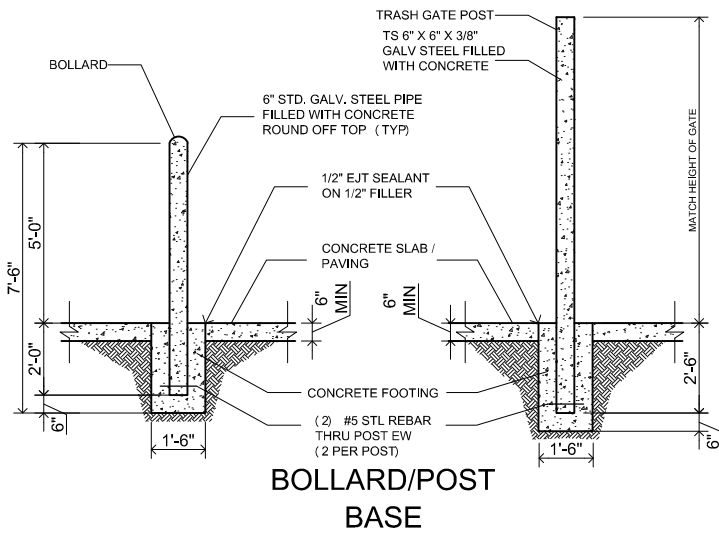

The information in this report is confidential and may be legally privileged. It is intended solely for the internal use of Community Waste Disposal, L.P. (CWD). Access to the information contained within this report by anyone else is unauthorized. Any disclosure, copying, distribution or action taken or omitted based on this information is prohibited and maybe unlawful.



Community Waste Disposal
Since 1984
2010 California Crossing Road
Dallas, Texas 75220-2810
972.392.9300 • 817.795.9300
972.392.9301

SINGLE DUMPSTER

AUGUST 23 2018

GUIDELINES
SCALE: 3/16" = 1'

SRG Architects, LLC

TBAE FIRM #BR 2117
www.sarrogroup.com
Ph: 852.708.3161
6421 Camp Bowie Blvd., Suite 312
Fort Worth, Texas 76116
Copyright © 2018 SRG Architects, LLC



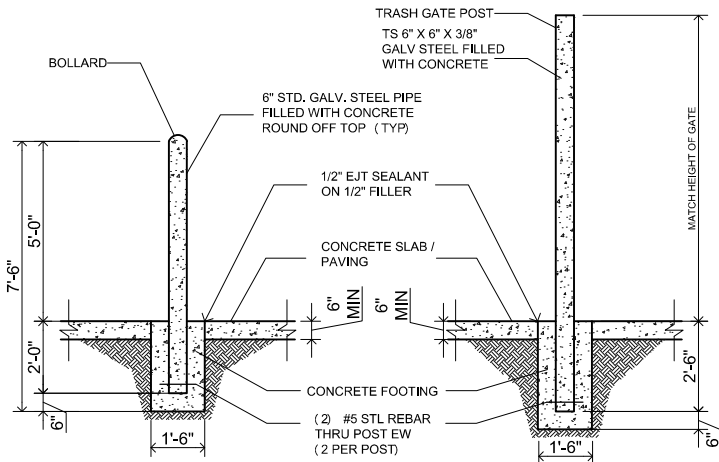

**BOLLARD/POST
BASE**

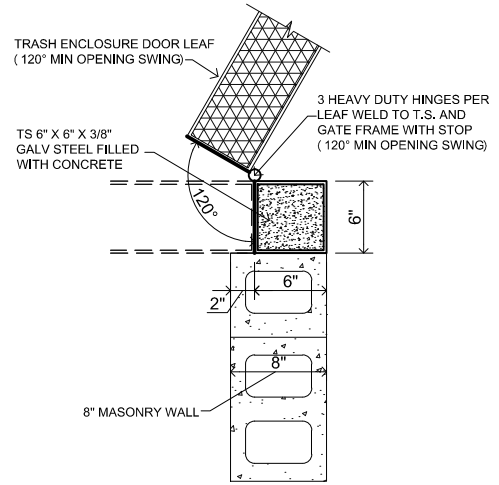

HINGE DETAIL

SCALE: 3/4" = 1'

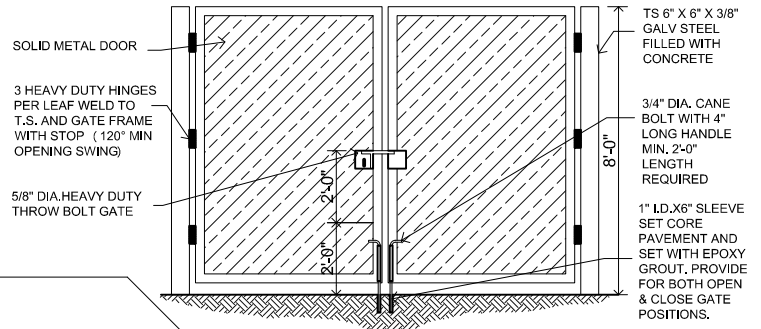

CANE BOLT DETAIL

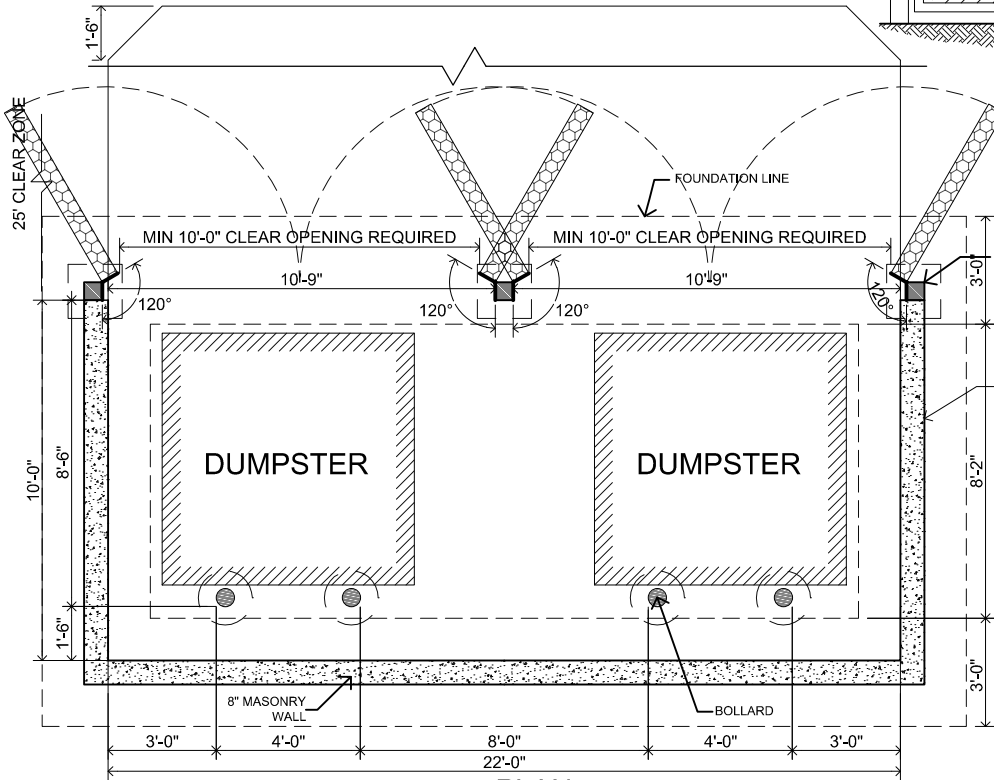

PLAN

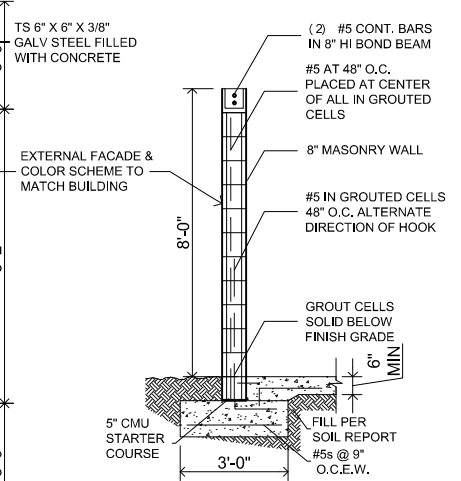

SECTION

The information in this report is confidential and may be legally privileged. It is intended solely for the internal use of Community Waste Disposal, L.P. (CWD). Access to the information contained within this report by anyone else is unauthorized. Any disclosure, copying, distribution or action taken or omitted based on this information is prohibited and maybe unlawful.



Community Waste Disposal
Since 1984
2010 California Crossing Road
Dallas, Texas 75220-2810
972.392.9300 • 817.795.9300
972.392.9301

DOUBLE DUMPSTER

AUGUST 23 2018

**GUIDELINES
SCALE: 3/16" = 1'**

SRG Architects, LLC

TBAE FIRM #BR 2117
www.sarrogroup.com
Ph: 882.708.3161
6421 Camp Bowie Blvd., Suite 312
Fort Worth, Texas 76116
Copyright © 2018 SRG Architects, LLC



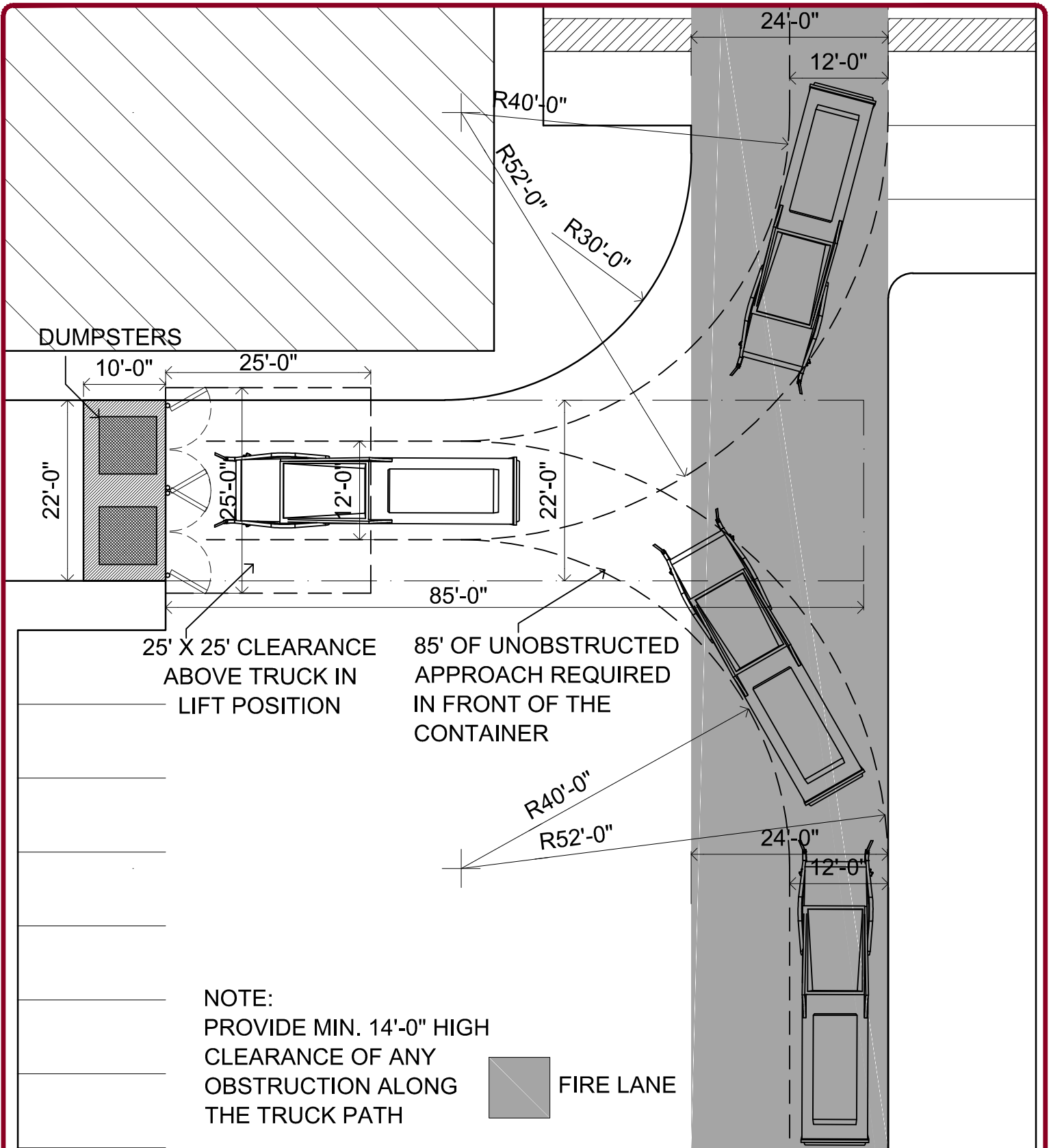

The information in this report is confidential and may be legally privileged. It is intended solely for the internal use of Community Waste Disposal, L.P. (CWD). Access to the information contained within this report by anyone else is unauthorized. Any disclosure, copying, distribution or action taken or omitted based on this information is prohibited and maybe unlawful.



Community Waste Disposal.com
 2010 California Crossing Road
 Dallas, Texas 75220-2310
 Telephone: 972.392.9300 • 817.795.9300
 Facsimile: 972.392.9301

**FRONT LOAD TRUCK
 TURNING RADIUS
 DOUBLE DUMPSTER**

JUNE 28 2018

**GUIDELINES
 SCALE: 1/16" = 1'**

SRG Architects, LLC

TBAE FIRM #BR 2117
 www.sanrogroup.com
 Ph: 682.708.3161
 6421 Camp Bowie Blvd., Suite 312
 Fort Worth, Texas 76116

Copyright © 2018 SRG Architects, LLC



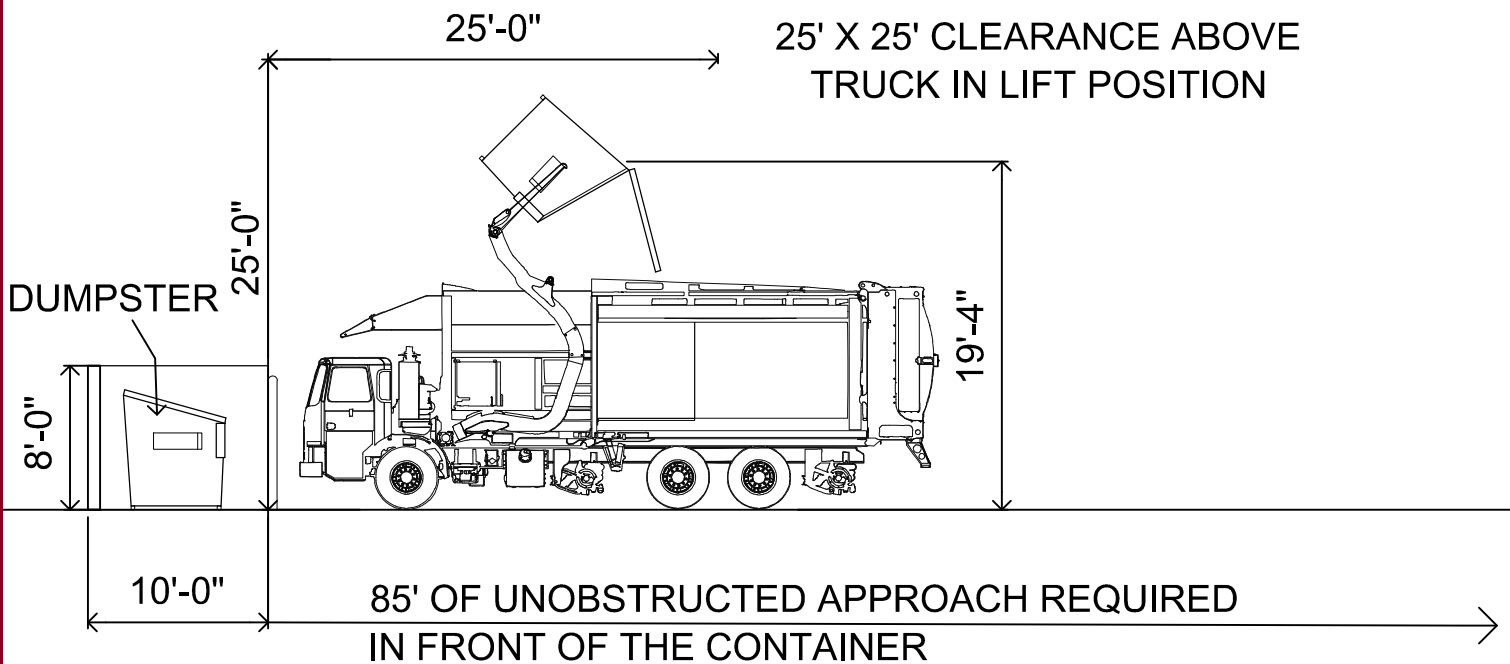
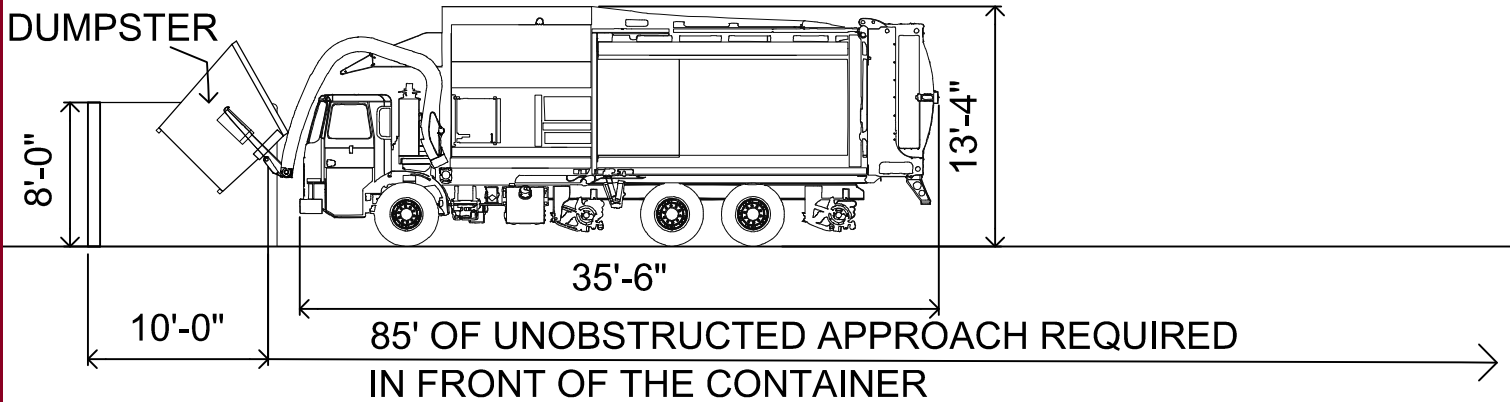

The information in this report is confidential and may be legally privileged. It is intended solely for the internal use of Community Waste Disposal, L.P. (CWD). Access to the information contained within this report by anyone else is unauthorized. Any disclosure, copying, distribution or action taken or omitted based on this information is prohibited and maybe unlawful.



Community Waste Disposal
Since 1984
 2010 California Crossing Road
 Dallas, Texas 75220-2310
Telephone
 972.392.9300 • 817.795.9300
Facsimile
 972.392.9301

FRONT LOAD TRUCK SIDE ELEVATION

AUGUST 2 2018

GUIDELINES
SCALE: 3/32" = 1'

SRG Architects, LLC
 TBAE FIRM #BR 2117
 www.sanrogroup.com
 Ph: 832.708.3161
 6421 Camp Bowie Blvd., Suite 312
 Fort Worth, Texas 76116
 Copyright © 2018 SRG Architects, LLC



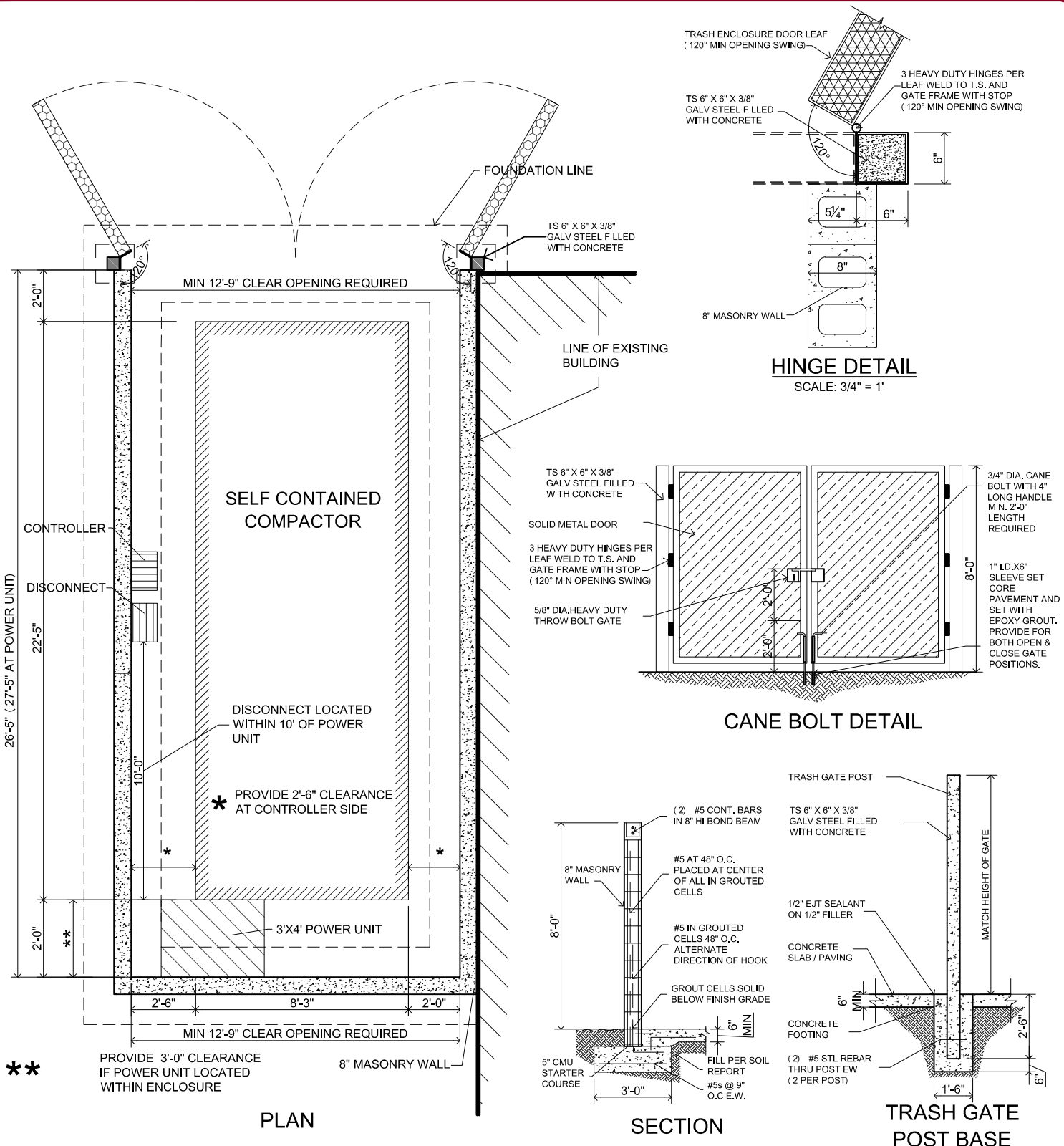

The information in this report is confidential and may be legally privileged. It is intended solely for the internal use of Community Waste Disposal, L.P. (CWD). Access to the information contained within this report by anyone else is unauthorized. Any disclosure, copying, distribution or action taken or omitted based on this information is prohibited and maybe unlawful.



Community Waste Disposal.com
 2010 California Crossing Road
 Dallas, Texas 75220-2810
 972.392.9300 • 817.795.9300
 972.392.9301

**SELF CONTAINED COMPACTOR
 ENCLOSURE PLAN**

AUGUST 23 2018

**GUIDELINES
 SCALE: 3/16" = 1'**

SRG Architects, LLC

TBAE FIRM #BR 2117
 www.sanrogroup.com
 Ph: 882.708.3161
 6421 Camp Bowie Blvd., Suite 312
 Fort Worth, Texas 76116

Copyright © 2018 SRG Architects, LLC



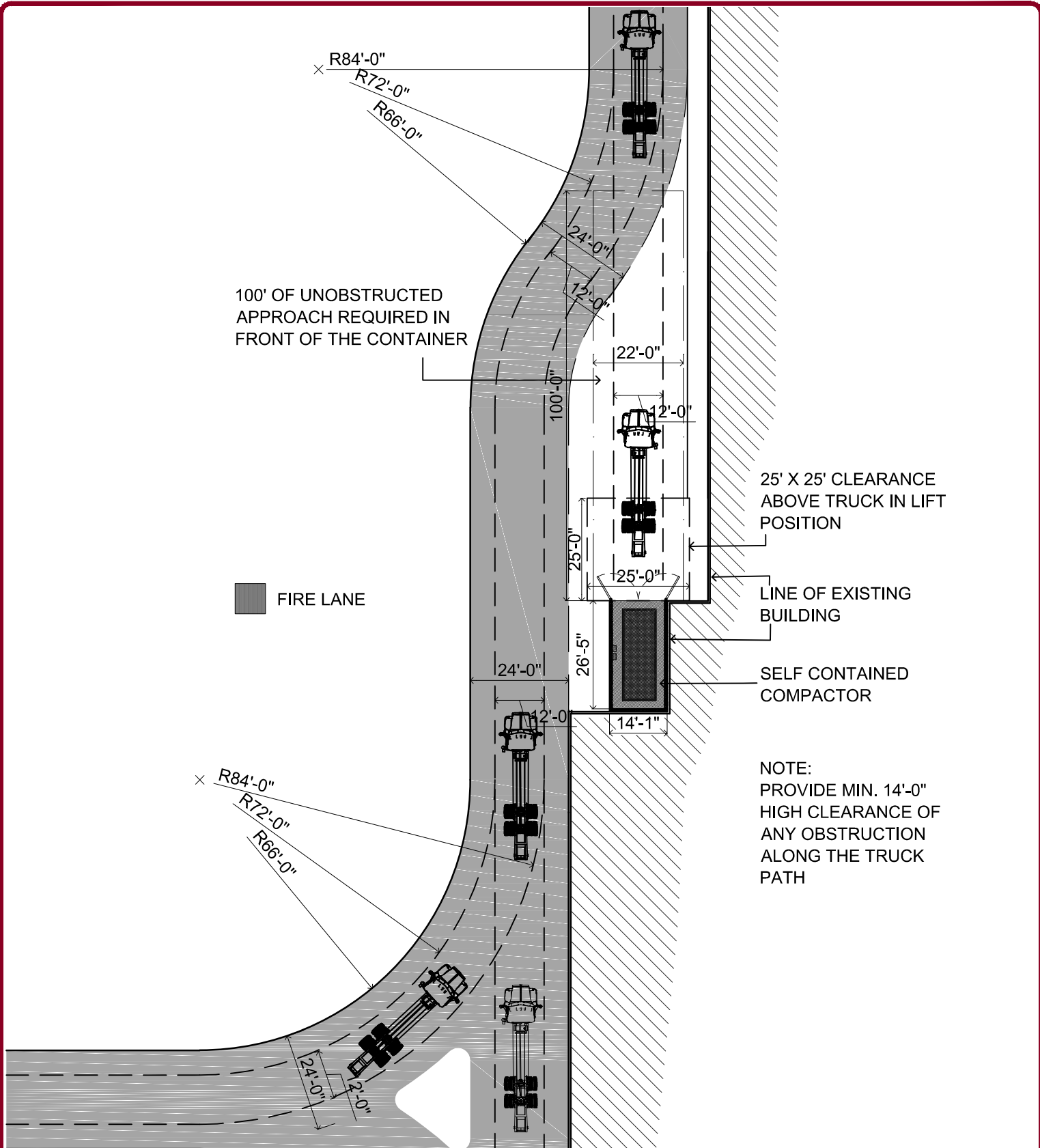

The information in this report is confidential and may be legally privileged. It is intended solely for the internal use of Community Waste Disposal, L.P. (CWD). Access to the information contained within this report by anyone else is unauthorized. Any disclosure, copying, distribution or action taken or omitted based on this information is prohibited and maybe unlawful.



Community Waste Disposal.com
 Since 1984
 2010 California Crossing Road
 Dallas, Texas 75220-2310
 Telephone: 972.392.9300 • 817.795.9300
 Facsimile: 972.392.9301

**ROLL OFF TRUCK
 TURNING RADIUS**

JUNE 28 2018

**GUIDELINES
 SCALE: 1/32" = 1'**

SRG Architects, LLC

TBAE FIRM #BR 2117
 www.sanrocgroup.com
 Ph. 682.708.3161
 6421 Camp Bowie Blvd., Suite 312
 Fort Worth, Texas 76116
 Copyright © 2018 SRG Architects, LLC



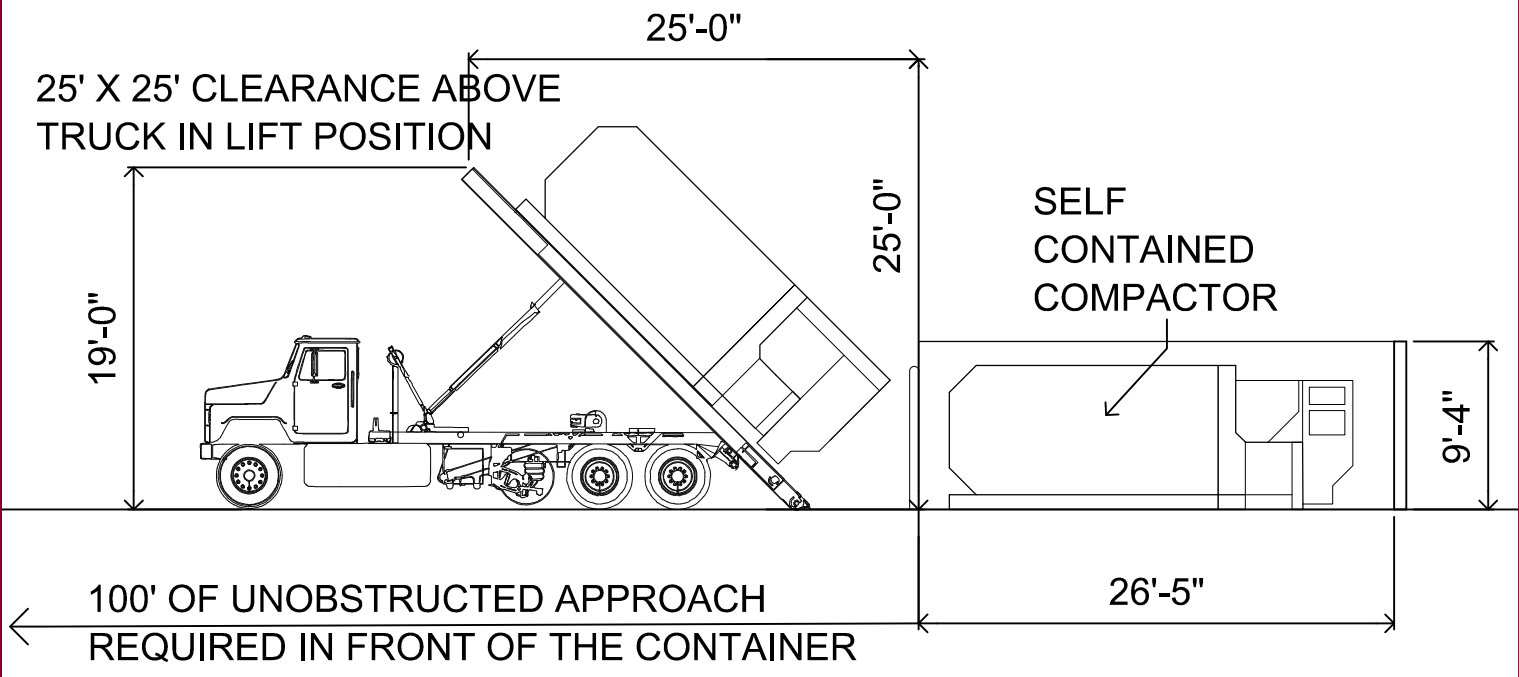
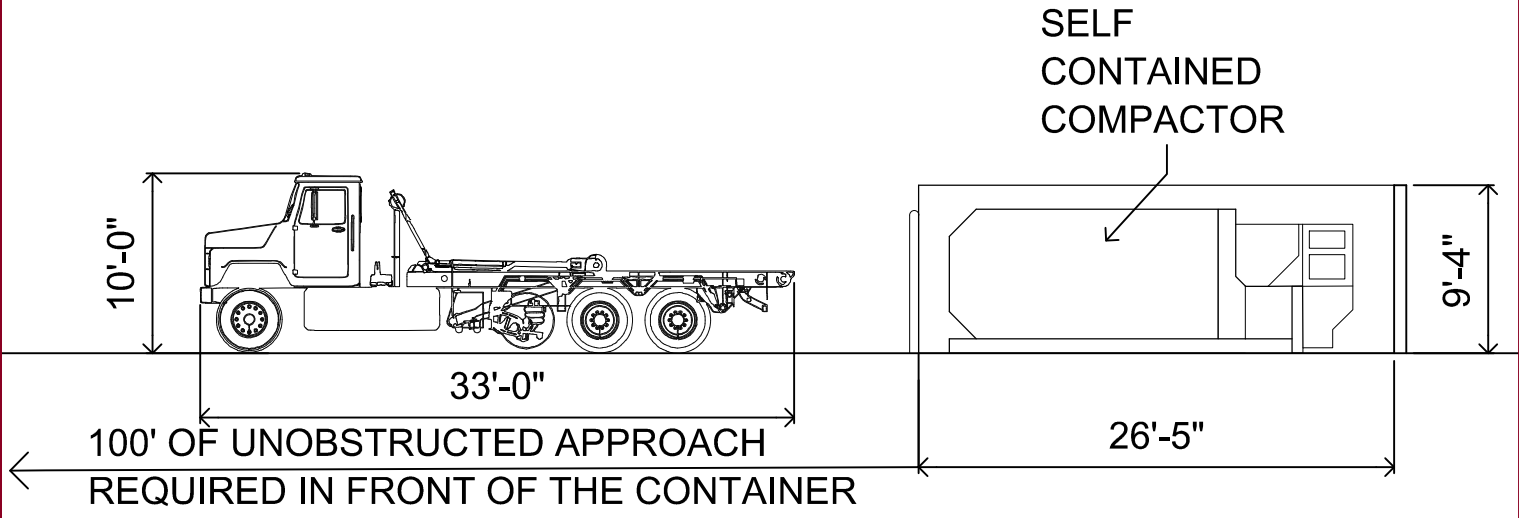

The information in this report is confidential and may be legally privileged. It is intended solely for the internal use of Community Waste Disposal, L.P. (CWD). Access to the information contained within this report by anyone else is unauthorized. Any disclosure, copying, distribution or action taken or omitted based on this information is prohibited and maybe unlawful.



Community Waste Disposal.com
 2010 California Crossing Road
 Dallas, Texas 75220-2310
 Telephone 972.392.9300 • 817.795.9300
 Facsimile 972.392.9301

ROLL OFF TRUCK SIDE ELEVATION

AUGUST 2 2018

GUIDELINES
 SCALE: 3/32" = 1'

SRG Architects, LLC

TBAE FIRM #BR 2117
 www.sanrogroup.com
 Ph: 832.708.3161
 6421 Camp Bowie Blvd., Suite 312
 Fort Worth, Texas 76116
 Copyright © 2018 SRG Architects, LLC



Self-Contained Compactors

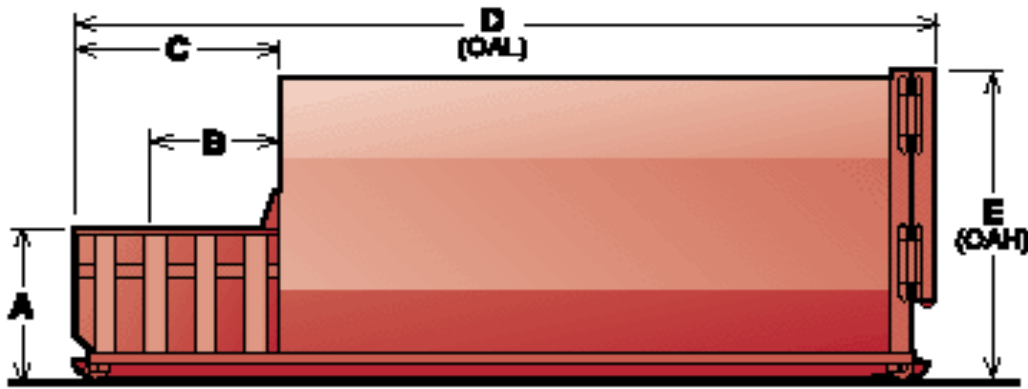

	A	B	C	D**	E	LBS.
15 cu yds	4' - 0" 1219 mm	3' - 7- 1/4" 1099 mm	5' - 7- 1/2" 1715 mm	14' - 3" 4344mm	7' - 5" 2261 mm	8860 lbs. 4173 kg
20 cu yds	4' - 0" 1219 mm	3' - 7- 1/4" 1099 mm	5' - 7- 1/2" 1715 mm	17' - 4" 5284 mm	7' - 5" 2261 mm	9520 lbs. 4318 kg
25 cu yds	4' - 0" 1219 mm	3' - 7- 1/4" 1099 mm	5' - 7- 1/2" 1715 mm	17' - 10- 1/2" 5449mm	8' - 8" 2642 mm	10030 lbs. 4550 kg
30 cu yds	4' - 0" 1219 mm	3' - 7- 1/4" 1099 mm	5' - 7- 1/2" 1715 mm	20' - 5" 6223 mm	8' - 8" 2642 mm	10620 lbs. 4818 kg
35 cu yds	4' - 0" 1219 mm	3' - 7- 1/4" 1099 mm	5' - 7- 1/2" 1715 mm	22' - 5" 6833 mm	8' - 8" 2642 mm	11130 lbs. 5049 kg

Standard CWD Self Contained Compactor size is 35 cu yd.

*Sizes are approximate and may vary by manufacturer

Stationary Compactors

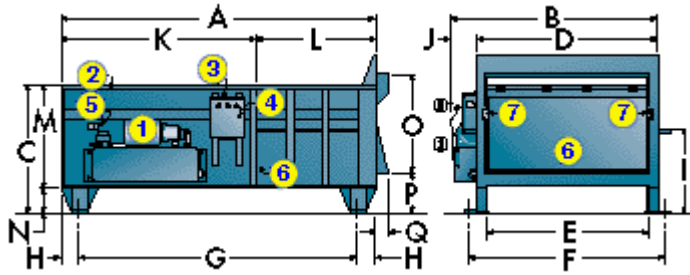

1	Side Mount Power Unit
2	Power Unit Weather Cover
3	Control Panel Box
4	Motor Starter Reset Button
5	Limit Switch
6	Ram
7	Ram Guide Shoes with Replaceable Wear Strips

A B C D E F *G *H I

119 1/2"	79"	48 9/16"	69 1/8"	60"	75"	106 1/2"	6 1/2"	31 1/2"
----------	-----	----------	---------	-----	-----	----------	--------	---------

3035 mm 2007 mm 1233 mm 1756 mm 1524 mm 1905 mm 2705 mm 165 mm 800 mm

J K L M N O P Q

9 1/2"	73 3/4"	45 3/4"	39 9/16"	9"	38 1/2"	14 5/8"	5"
--------	---------	---------	----------	----	---------	---------	----

241 mm 1873 mm 1162 mm 1005 mm 229 mm 978 mm 371 mm 127 mm

- At Bolt Centers (reference dimensions only)
- Sizes are approximate and may vary by manufacturer.

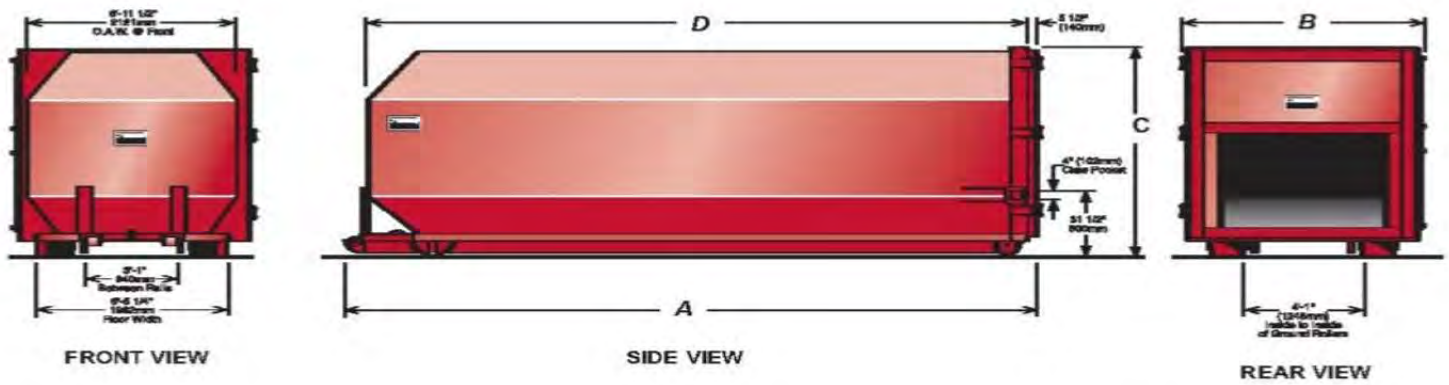

<i>Model No.</i>	<i>A</i>	<i>B</i>	<i>C</i>	<i>D</i>	<i>Capacity</i>	<i>Max Force Rate</i>	<i>Weight (Approx.)</i>
RJ-40 OC	22'-2" 6756mm	8'-0" 2438mm	8'-8" 2642mm	20'-11" 6375mm	40 cy 31m ³	80,000 lbf 355.8 kN	6700 lb 3039 kg



Industries, Inc.
Systems that Work!

Self-contained Roll-off Compactor / Containers



SCS-2235



Mini-SCS system with truncated container



SCS model with raised compactor

- Unitized construction & adjustable door with seal retains high-liquid waste.
- Controls and reduces odor / pest problems.
- Available with 1.5 or 2 cu. yd. capacity compactor.
- Available in 16', 18', 20', 22', and 24' lengths.
- Customized loading applications with security chutes, hoppers, and decks.
- Customized designs available including space saving narrow or short container construction.
- Remote power unit.
- Secure safety door locking system with catch and cam locked, ratchet load binder.
- Oil spill pan positioned under hydraulic disconnect maintains a clean, safe working area.
- Container inspection/fire port standard.
- Double end pick-up on standard universal and deadlift understructures.
- Nylatron ram guide system.
- Conforms to current ANSI Z245 Standards.
- Industry's leading warranty program.

Quality Equipment Built with Pride

Specifications

Compactor Specifications

Model	SC	SCS
Mfr's Rating (cu. yds.)	1.5	2
WASTE Type Rating (cubic yards)	1.03	1.57
Clear Top Opening (in.)		
Length	31	40
Width	58	56.5
Chamber Length (in.)	32	42
Ram Stroke (inches)	42	46.5
Ram Penetration (in.)	10	5.5
Force Rating (Ram PSI at Stated Forces/Lbs.)	29.5/44,200	27.6/49,200
Hydraulic System Pressure	2,250	2,250
Ram Face (inches)		
Width	60	59.5
Height	25	30
Cycle Time (seconds)	38	36
Volume Displacement (cubic yards/hour)	99	158
Motor H.P.	10	10
Pump Volume G.P.M.	10	10
Oil Reservoir (gallons)	25	25

Material Specifications

Model	SC	SCS
Compactor Frame		
Floor Plate	3/8" 1045/AR 235	3/8" 1045/AR 235
Floor Plate Supports	TS 2" x 2" x 3/16" Bar 2" x 1/2"	TS 2" x 2" x 3/16" Bar 2" x 1/2"
Side Plates	1/4"	1/4"
Side Supports	6" x 2-1/2" 10 GA Formed Channel	6" x 2-1/2" 10 GA Formed Channel
Breaker Bar	L 6" x 6" x 1/2" & TS 2" x 6" x 1/4" w/Retainer Teeth	L 6" x 6" x 1/2" & TS 2" x 6" x 1/4" w/Retainer Teeth
Ram Hold Down Bars	1" x 1-1/2" Bar	1" x 1-1/2" Bar
Ram		
Face Plate	1/2"	1/2"
Floor Plate	1/2"	1/2"
Side Plates	1/4"	1/4"
Top Plate	1/4"	1/4"
Top Plate Supports	C 4" x 5.4#	C 4" x 5.4#
Container		
Floor & Side Plate	7 GA	7 GA
Floor Supports (on 20" Centers)	C 3" x 4.1#	C 3" x 4.1#
Roof Plate	10 GA	10 GA
Main Rails	TS 2" x 6" x 1/4"	TS 2" x 6" x 1/4"
Bull Nose	1-1/4" Solid Steel Burn-out	1-1/4" Solid Steel Burn-out
Wheels (4 total)	5"W x 6-5/8" D	5"W x 6-5/8" D

Standard Controls & Features

Cylinder(s): SC - (1) 5" Bore x 2-1/2" Rod x 42" Stroke
SCS - (2) 4" Bore x 2-1/2" Rod x 34" Stroke

Automatic Multicycle System
Multi Minute Cycle Timer
Panel Mounted: Key Locked Start Button
Emergency Stop Button
Reverse Button

Tri-volt Selection (208, 230 or 460, 3 Phase)
Pressure Switch Soft-shift System
Monitor Gauge (Advance Full/Full Load Warning Pressure Gauge)
Oil Suitable for Wide Temperature Range (-40° F Pour Point)
10' Hydraulic Hoses with Quick Disconnects
Provisions for Quick Disconnects Mounted on Left and Right Hand Sides
Oil Spill Pan Mounted Under Both Quick Disconnect Locations
Oil Level Gauge with Thermometer
10' Power Supply Cable
Removable Compactor Access Panel
Nylatron Ram Guide System
Octagon Container
Rear Container Door: Full Seal
Ratchet Locking System
Heavy Duty Adjustable Hinge System

Four Wheels with Grease Fittings
Universal or Deadlift Understructure with Double End Pick-up
Container Inspection Port

Optional Features

Remote Control Station with 10' Cable
Keyed Jog Controls
Advance Full Load Indicator
Low/Hot Oil Indicator Light with Shut-off
Thermo Oil Heater
TEFC Motor
Deodorizer or Disinfectant Spray System
Power Unit Cover with Lockable Door
Walk-on and Heavy Duty Decks
Safety Hand and Toe Rails
Rear or Side Load Hoppers
Rear or Side Load Security Chutes
Dog House Hoppers with Interlocked Door(s)
Container Centering Guide
Rectangular or Special Container Style
Double End Pick-up for Dempster and Hooklift Understructures
Special Understructures
Special Shortened or Cut-down Container
Wear Strips on Main Rails
Heavy 6" x 2" x 3/8" Main Rails
Low Profile Compactor

Contact Your Local Representative for Additional Options

Specifications

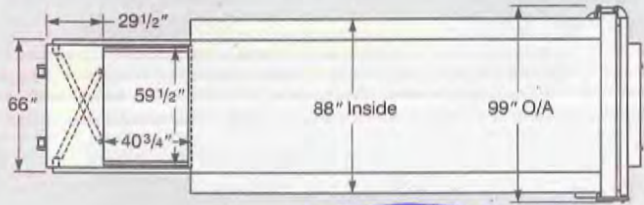

SCS Model

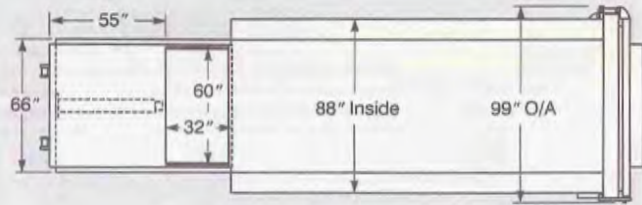

SC Model

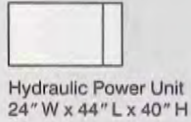
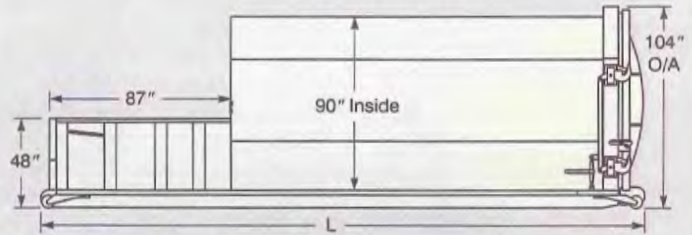
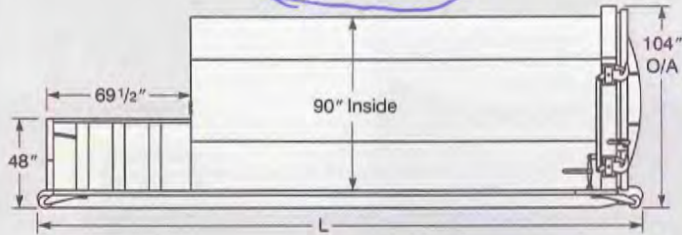

Hydraulic Power Unit
24" W x 44" L x 40" H

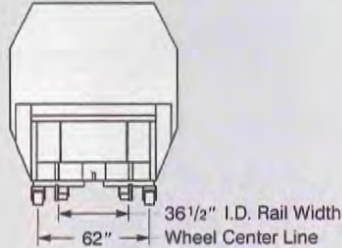

**Compactor End
Universal Understructure**

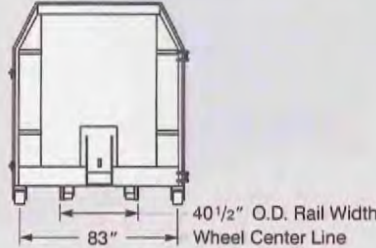

**Container End
Universal Understructure**

Conforms to Current
ANSI Standards
ANSI Z245.2 Stationary Compactors
Safety Requirements
ANSI Z245.30 Waste Containers
Safety Requirements
ANSI Z245.60 Waste Containers
Compatibility Dimensions

Model	SC 1619	SC 1822	SC 2026	SC 2231	SC 2435	SCS 1623	SCS 1827	SCS 2031	SCS 2235	SCS 2439
Capacity - Cubic Yards**	19	23	27	31	35	23	27	31	35	39
Compactor & Container - O/A Length (L)*										
Universal Understructure	18' 4-1/2"	20' 4-1/2"	22' 4-1/2"	24' 4-1/2"	26' 4-1/2"	18' 4-1/2"	20' 4-1/2"	22' 4-1/2"	24' 4-1/2"	26' 4-1/2"
Deadlift Understructure	18' 7"	20' 7"	22' 7"	24' 7"	26' 7"	18' 7"	20' 7"	22' 7"	24' 7"	26' 7"
Hooklift Understructure	19' 3"	21' 3"	23' 3"	25' 3"	27' 3"	19' 3"	21' 3"	23' 3"	25' 3"	27' 3"
Hooklift Understructure w/Fold-down, Compactor End Hook	19' 5"	21' 5"	23' 5"	25' 5"	27' 5"	19' 5"	21' 5"	23' 5"	25' 5"	27' 5"
Compactor & Container - Weight (Lbs.)	9,650	9,960	10,630	11,300	11,970	9,140	9,810	10,480	11,150	11,820
Remote Power Unit with Oil - Weight (Lbs.)	550	550	550	550	550	550	550	550	550	550

* Check that the overall length of the unit does not exceed the maximum length that the hoist can haul. Special understructures may change the overall length of the machine, check with the factory for confirmation.

** A frame pull understructure is available. It will reduce the length of the unit by 10" and the capacity by approximately 1.3 cubic yards.

CAUTION! This equipment should be operated by properly trained personnel. Improper use, misuse or lack of maintenance could cause injury to people and/or property. Photos used in this brochure are illustrative only. Due to its commitment to quality SP Industries' specifications are subject to change without notice to accommodate improvements to its equipment. Information contained within this literature is intended to be the most accurate available at the time of printing.



The remote power unit can be placed in any convenient location for protection from weather, accidents, and vandalism. All electrical components are UL listed.



Typical Installations

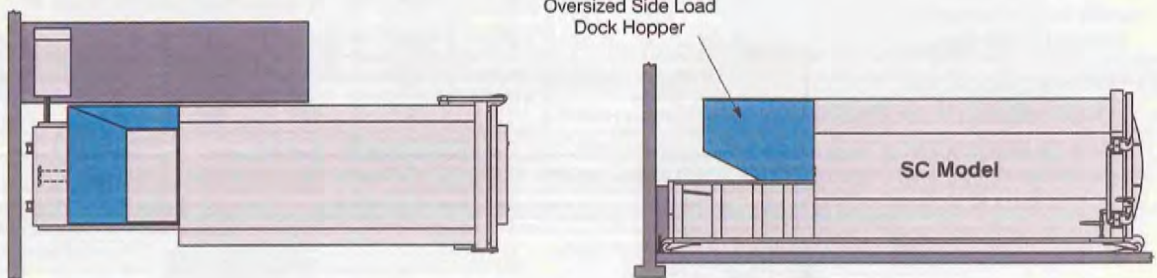
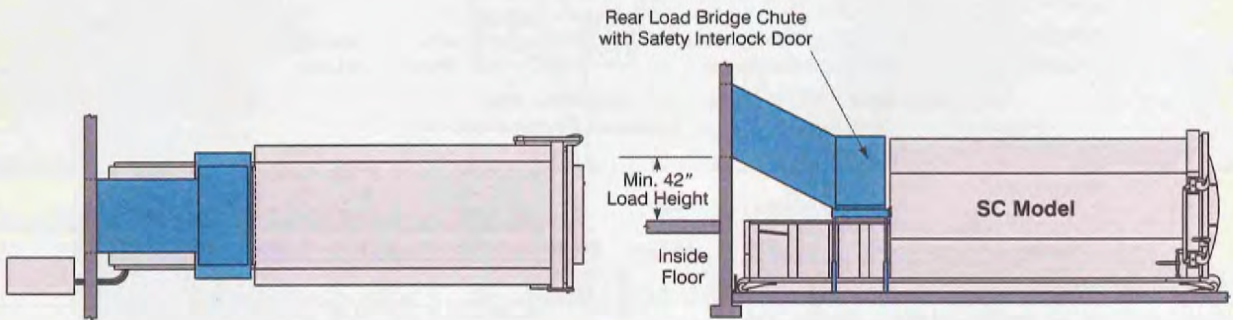
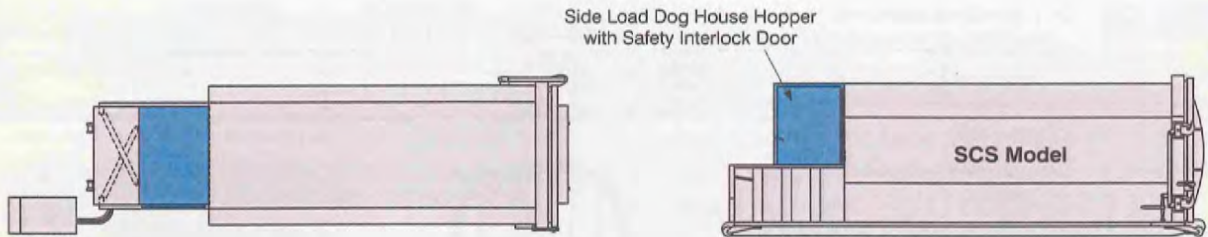
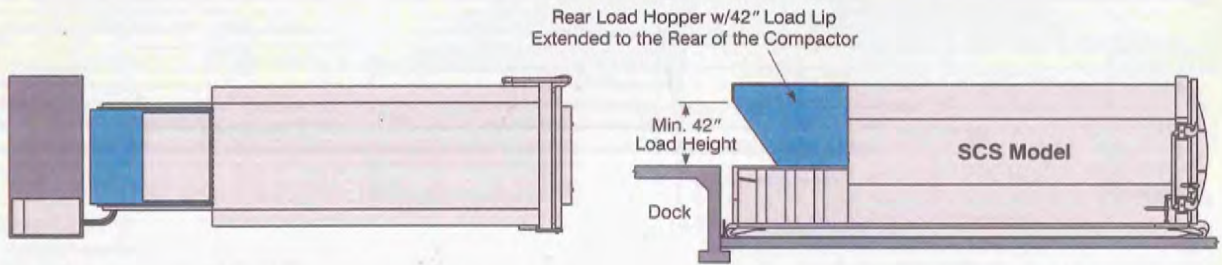

WASTE EQUIPMENT
TECHNOLOGY ASSOCIATION



ENVIRONMENTAL INDUSTRY
ASSOCIATIONS

Distributed By:



SP INDUSTRIES, INC.
2982 Jefferson Road
Hopkins, MI 49328

Phone: 800.592.5959 or 269.793.3232
Fax: 269.793.3232
Web: www.sp-industries.com
Email: info@sp-industries.com

Self Contained Compactor - Trash

Its well-engineered design, reliability and unique features make it a customer favorite.



Equipment Description

Self contained compactors are a good solution for properties that want to limit the escape of high liquid waste while controlling odor and pest problems. Because waste is compacted, the haul frequency is much less when compared with front load service.

Optional features include a custom loading application with security chutes, hoppers, and dock-side loading. Available for rental or purchase in sizes 15-35 yards, the equipment can be customized to your business.



Service

Services are available Monday through Saturday and may be requested by calling the CWD Customer Service Department at 972.392.9300, Option 2. A representative will schedule pickups, repairs, cleanings, and more. For pricing or an increase or decrease in service, please contact your CWD Sales Rep directly.

Installation

A **Quick Disconnect Box** must be provided within 10 feet of the compactor. In addition, one of the following is required:

- 460 volt, 3 phase, with 35 amp breaker, or
- 230 volt, 3 phase with 70 amp breaker, or
- 208 volt, 3 phase with 80 amp breaker, or
- 230 volt, single phase with 125 amp breaker

Equipment Delivery, Certification & Maintenance

Whether it is purchased or rented from CWD, the equipment will be custom designed for your business. All equipment meets OSHA and UL requirements. CWD will provide any maintenance or equipment needed during the rental agreement term.